

Vertical balers

B-series



Baler B50

For optimal transport logistics

The B50 baler offers efficient compaction into dense bales with ideal dimensions for optimal transport logistics.

Perfect pallet size bales

Bales measure 1200 mm x 800 mm x 1100 mm and fit on a standard EUR pallet.

Highlights

- Machine design and demountable cylinder give a low transport height
- Front placed strap rolls enable installation against the wall
- Uses standard 16A outlet
- Short press cycle
- Low noise level of just 62-64 dB
- High compression ratio
- Produces large bales (minimum 400 kg cardboard)

Optional Extras



A sliding door stays open by default and gives you hands-free waste filling.



Balers are available in other RAL colours which you may choose.



Gain remote control of your baler with our intelligent fleet monitoring system, BRA-IN.

Product details

Baler B50



Whisper

30 dB



Refrigerator

50 dB



B50 baler

62-64 dB

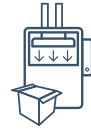

Other balers

75 dB

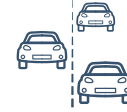

Cars on highway

100 dB



Turbojet engine

160 dB

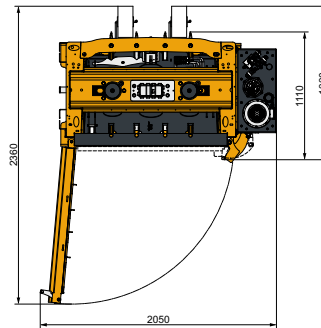
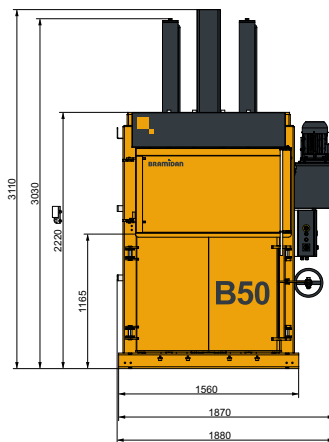

Technical specifications

Bale size WxDxH (mm)	1200 x 800 x 1100
Feed opening WxH (mm)	1200 x 565
Power supply	3x400V 50Hz 16A
Motor (kW)	5.5
Cycle time avg. (sec)	26
Dimensions WxDxH (mm)	1870 x 1330 x 3110
Machine weight (kg)	1800
Stroke (mm)	900
Number of ties	4
Type of tying	Twine / Steel wire
Full bale light	Yes
Bale eject	Automatic



Bale weight

Cardboard (kg) 400-500
Plastic foil (kg) 450-550



Press force

50 t



Noise level

62-64 dB



Waste types

Cardboard, plastic foil, paper

BRAMIDAN
www.bramidan.com

Bramidan A/S
Industrivej 69
6740 Bramming
Denmark
Tel: +45 7517 3266
bramidan@bramidan.dk