

Vertical balers

X-series



Baler X10

Small and efficient baler

This machine has a press force that is superior compared to other balers of this size.

Ergonomic and safe operation

An easy two-button maneuver ejects the bale. This eliminates heavy lifting.

Highlights

- Compact and strong
- Internal cross cylinders for a very low overall height (1900 mm)
- Short cycle time for fast clean up
- Press force of 10 tons – a hardworking baler with high capacity
- Small base area (<1.5 m2)
- Steady compaction – keeps bales under pressure while tying

Optional Extras



Balers are available in other RAL colours which you may choose.



Top-mounted strap holder lets you install your baler close to the wall.



Get online access to your balers with our monitoring system called BRA-IN.

Product details

Baler X10



Whisper

30 dB



Refrigerator

50 dB



X10 baler

59-60 dB



Other balers

75 dB

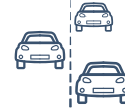

Cars on highway

100 dB



Turbojet engine

160 dB

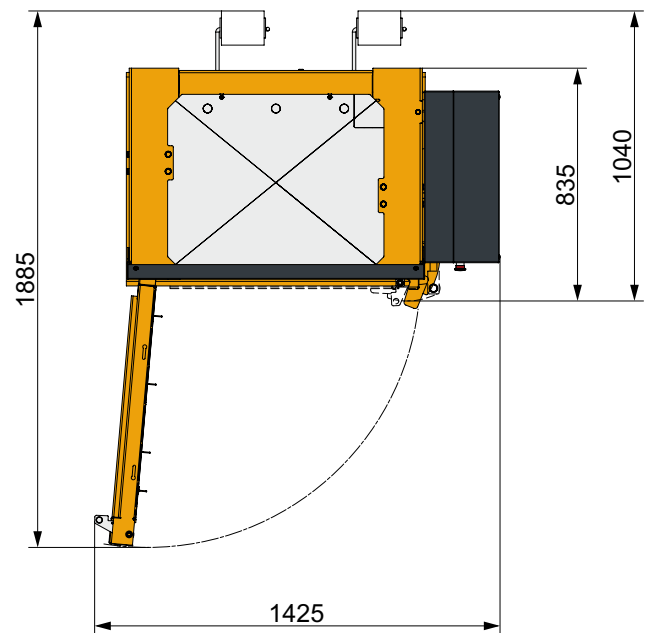
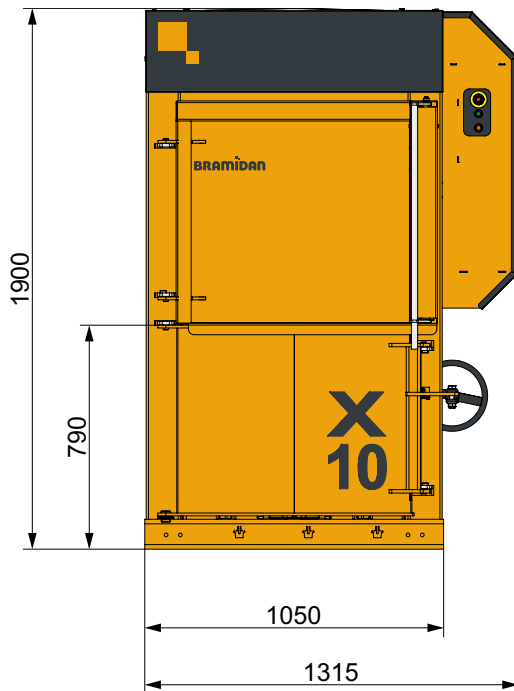

Technical specifications

Bale size WxDxH (mm)	800 x 600 x 600
Feed opening WxH (mm)	800 x 610
Power supply	1x230V / 3x400V 50Hz
Motor (kW)	4.0
Cycle time avg. (sec)	38 / 18
Dimensions WxDxH (mm)	1315 x 1040 x 1900
Machine weight (kg)	665
Stroke (mm)	845
Number of ties	3
Type of tying	Twine
Full bale light	Yes
Bale eject	Automatic



Bale weight

Cardboard (kg)	70-90
Plastic foil (kg)	80-110



Press force

10 t



Noise level

59-60 dB



Waste types

Cardboard, plastic foil, paper, PET bottles, alu cans, tin cans, plastic hard, textile, EPS.

BRAMIDAN
www.bramidan.com

Bramidan A/S
Industrivej 69
6740 Bramming
Denmark
Tel: +45 7517 3266
bramidan@bramidan.dk